

Simple Dew Digital Dew Point Analyzer



For measurement of:

- Endothermic Atmosphere
- Endothermic Generators
- Nitrogen / Methanol Atmosphere
- Nitrogen / Hydrogen Atmosphere
- Plant Air Systems

SSi Super Systems Inc.

Product Manual – Simple Dew - Dew Point Analyzer

SPECIFICATIONS –

Measurement Range:	0 to +80°F (-18 to +27°C)
Temperature Range:	0 to +120°F (-18 to +49°C)
Power Supply:	115 to 230 VAC (universal input)
Retransmission Output:	0-1 Volt (range is –50 to +80°F)
Size (Closed Case):	15.25” x 9” x 6.25” (approximately)
Weight:	8.2 lbs (3.7 kg)

TABLE OF CONTENTS –

SPECIFICATIONS –	2
TABLE OF CONTENTS –	2
INTRODUCTION –	2
WARNINGS –	3
STARTUP –	3
OPERATION –	3
INSTRUMENT DAMAGE –	4
WHAT IS DEW POINT?	5
HOW IT WORKS –	6
MAINTENANCE / SAFETY ISSUES –	6
FACTORY CALIBRATION –	6
FIELD CALIBRATION –	6
SPARE PARTS –	11
RETURNING THE UNIT TO SSI –	12
REVISION HISTORY –	12
APPENDIX “A” – (DETERMINING THE SENSOR TEMPERATURE IN °F).....	13
APPENDIX “B” – (DETERMINING THE SENSOR TEMPERATURE IN °C).....	14
.....	14
APPENDIX “C” – (DETERMINING THE DEW POINT IN °F).....	15
APPENDIX “D” – (DETERMINING THE DEW POINT IN °C).....	16
REVISION HISTORY.....	17

INTRODUCTION –

Thank you for selecting Super Systems Inc. and the Simple Dew as your source for accurate dew point measurements.

We have taken every precaution to protect this unit during shipment. Carefully unpack the Simple Dew - Dew Point Analyzer. If there are any signs of shipping damage, notify SSI and the shipper immediately.

SSi Super Systems Inc.

Product Manual – Simple Dew - Dew Point Analyzer

Keep this instruction book in a secure place and refer to it when there is a question about the analyzer. An electronic version of this manual can be downloaded for free from our website: www.supersystems.com.

WARNINGS –

Although it is intended for use in an industrial environment, the Simple Dew is a sensitive piece of analysis equipment. Care should be taken not to drop the analyzer or to operate it in a manner inconsistent with its intended use.

- Open all sample ports and remove all soot and/or moisture from the lines prior to attaching the sample tubing for the first time.
- The analyzer should be stored at ambient temperature (65-80°F) for at least two hours prior to operation.
- If the unit is to be returned to SSi for service or any other reason, protect the instrument with at least four inches of foam or other impact-absorbing material on all sides and place it in an appropriately sized cardboard box.
- This unit is not designed to measure the dew points in corrosive gasses, such as Ammonia, SO₃, Chlorine, and HCL.
- Please read and understand this Product Manual before operating the unit.

Failure to comply with these conditions may cause damage to the unit that will not be covered under the warranty. Super Systems, Inc. is not responsible for damage to this unit caused by disregard of these warnings, neglect, or misuse.

STARTUP –

The Simple Dew - Dew Point Analyzer has been calibrated before it was shipped from Super Systems, Inc. You can begin typical operation as soon as the unit has been allowed to stabilize in a temperature similar to the temperature in the heat-treating department. This stabilization is particularly important for units that may have been sitting overnight in a delivery van in sub-zero weather. Rapid temperature change can cause condensation on the sensor which will cause the unit to temporarily display inaccurate readings.

OPERATION -

The use of the Simple Dew is somewhat dependent upon the application. For connection to an endothermic generator, no pump is required since the sample gas is under positive

SSi Super Systems Inc.

Product Manual – Simple Dew - Dew Point Analyzer

pressure. If this instrument is to be used on a furnace or other non-positive pressure application, an external sample pump will be required to deliver the gas to the sensor. Be sure that the filter (mounted to the bottom of the instrument) is clean and functional, since high accumulations of soot can hold moisture and influence the dew point measurement. It will also prevent soot and other contaminants from entering the unit and damaging the sensor.

The optimum flow rate of the sample gas should be between 1.5 and 2.0 Standard Cubic Feet per Hour (SCFH), although a flow rate as low as 1.0 SCFH is acceptable. If the unit is reading less than 1.0 SCFH, verify that there are no obstructions to the flow such as a clogged sample line or filter, or a poorly adjusted knob on the Simple Dew's flow meter.

Heat Treat Furnace Sampling: A gas sample must be extracted from the process using an external pump. The sample tube from which the sample is taken out of the furnace should extend into the furnace past the HOT face of the refractory. For accurate results, a designated sample port should be used to extract the sample. SSi offers two versions of sample port assemblies (part numbers 20263 and 20264) which are ideal for this purpose. If a designated sample port is not available, then a clean “burn-off” port on a Gold Probe™, an industry leading oxygen sensor for atmosphere control, can be used. Readings taken from the burn-off port on a probe may be artificially high due to the presence of soot in the probe sheath.

Endothermic Generator Sampling: For applications under pressure, the flow is controlled by the small restriction valve on the flow meter. A flow rate between 1.5 and 2.0 SCFH is ideal. The sample should be taken from the endothermic gas manifold after the gas has been cooled. **NOTE: Allow the sample port to blow out any soot and / or water before connecting the sample tube.** Failure to do so will result in inaccurate readings and expose the sensor to potential damage.

Instrument Damage –

The two main causes of damage to the Simple Dew are the ingestion of soot and water. Both of these contaminants will cause erroneous readings in the short term, and cause long-term damage to the sensor and internal components.

Soot / Particulate Contaminants

When taking a sample from a furnace or a generator, care should be taken to reduce the amount of soot that enters the instrument. The filter will trap these particles, but cleaning the sample line before attaching the Simple Dew will increase the life of the filter. Furnace ports can be burned off by pumping air through them while hot, or by removing them from the heat and mechanically cleaning them. Generator ports should be opened before the instrument is attached to allow any particulate buildup to be blown out. It is also helpful to tap on the port while it is being blown out to eject any loose particles before the instrument is attached.

SSi Super Systems Inc.

Product Manual – Simple Dew - Dew Point Analyzer

If soot is allowed to collect on the dew point sensor in the instrument, it could result in higher readings. This soot will also retain moisture than can corrode the sensor over time. The sensor tip can be cleaned by carefully removing it from the sample block (see Section 2.0 of the Field Calibration instructions) and rinsing it in isopropyl alcohol. The power should be off while this is done, and the power should remain off for at least 30 minutes after this procedure to allow all of the alcohol to completely evaporate.

Water / Moisture Contamination

When a furnace or generator is being started up or cooled down, the resulting gases will contain unusually high amounts of CO₂. When these gases cool, moisture will precipitate out and become condensation inside the sample tubing assembly. Even if the furnace or generator is operating normally, residual moisture may still be present in the sample tube or plumbing system. In the same way that the ports are checked for soot (see above) they should be checked for moisture before attaching the instrument. This is especially important when taking a sample from a generator, since the sample port is usually preceded by a significant amount of plumbing. All traces of moisture should be eliminated before attaching the instrument. Failure to do so will result in erroneous measurements and could result in damage to the analyzer.

The first signs of moisture in the instrument will be visible condensation collecting in the bowl filter and an unusually high dew point. The upper range of the sensor is +80°F, so if that value is displayed on the instrument it is probably due to the presence of moisture. If this moisture is not removed, it will cause the sensor tip to corrode and will eventually require the sensor to be replaced.

To remove moisture from the instrument, the filter should be removed from the instrument (since it will probably be wet) and an inert gas such as Nitrogen or Argon should then be flowed through the instrument for as much time as it takes to dry out. This dry-out time will depend on the amount of moisture present in the instrument. The condition of the sensor can be monitored by periodically reading the dew point from the display and watching the value decrease over time. To test if it is operating properly, verify the ambient dew point against a web-based weather station that will report the ambient dew point for your area. If the displayed reading is within three degrees of the reported dew point when the instrument is taken outside, then all of the moisture has probably been successfully removed. The wet filter and sample tubing can be re-attached after they have been completely dried out. The filter element will regain all of its original filtering properties after it has dried out.

To prevent the possibility of moisture damaging the instrument, be sure that the measured dew point is below ambient levels before it is stored. If necessary, Nitrogen or Argon can be used to purge the instrument after use.

WHAT IS DEW POINT?

Dew point can be defined as the temperature at which the water vapor pressure of the gas equals the saturated water vapor pressure. In other words, it is the temperature at which

SSi Super Systems Inc.

Product Manual – Simple Dew - Dew Point Analyzer

condensation will just begin to occur as the gas is cooled. Dew point and relative humidity are not the same measurement. Relative humidity is the amount of water vapor in the air compared to the amount the air could hold if it was totally saturated, and it is expressed as a percentage, not a temperature. To determine dew point, two main variables are required: Relative Humidity and Temperature. The Simple Dew measures both variables to compute the dew point.

HOW IT WORKS –

The dew point sensor is a “dielectric ceramic” that varies its electrical capacitance with changes in relative humidity. The sensor is mounted in a short probe, which is installed in a T-fitting that allows the sample gas to flow past the sensor. The tip of this probe contains the dielectric ceramic relative humidity (RH) sensor, as well as a built in temperature sensor to determine its dry bulb temperature. Information from both of these sensors is used to compute the resultant dew point.

MAINTENANCE / SAFETY ISSUES –

Maintaining proper sensor temperature will prevent the premature failure of the sensor. The operating temperature of the sensor should remain below 130° F (54°C) at all times. To determine the sensor temperature, measure the voltage between pins 5(+) and 9(-) on the microprocessor board. The voltage will be between 0 and 1VDC. Use the chart in Appendix A to determine the temperature in °F, or use Appendix B to determine the temperature in °C. If this temperature shows in excess of 130°F, the length of sample tubing should be increased to allow for adequate cooling of the sample before it passes the sensor tip.

FACTORY CALIBRATION –

Calibration of the sensor is recommended annually. SSi’s calibration is performed in our ISO/IEC 17025 certified laboratory, and includes an NIST traceable “Certificate of Calibration”. This certificate also indicates the accuracy of the analyzer before and after calibration. Please contact Super Systems, Inc. at (800) 666-4330 for more information regarding this service.

FIELD CALIBRATION –

It is also possible to calibrate the Simple Dew in the field, which will require the optional calibration kit (Part Number 31030). To perform this calibration, you will need the optional calibration kit (Part Number 31030) and a voltmeter that will allow you to measure between 0 and 1 volt DC. Since there is no display on the instrument itself, the voltages from the sensor circuit board will have to be translated into temperature and dew point measurements for the purpose of verifying the calibration. The instructions

SSi Super Systems Inc.

Product Manual – Simple Dew - Dew Point Analyzer

for doing this are contained in this document along with reference charts to aid in the interpretation of the voltages.

The calibration kit consists of two bottles of saturated salt solution in which each bottle generates a precise relative humidity percentage (R.H.%) value. One bottle is 11.3% R.H., and the other is 75.3% R.H. These two specific calibration points are already pre-programmed into the microprocessor board.

1.0 Locate the key components within the unit

- 1.1 The **microprocessor board** contains three very small buttons that are used for calibration. Two are next to one another, and they are marked “75.3%” and “11.3%”, while the other has no label. The unmarked button is the “Calibrate” button. The approximate locations of each button are shown on this diagram:

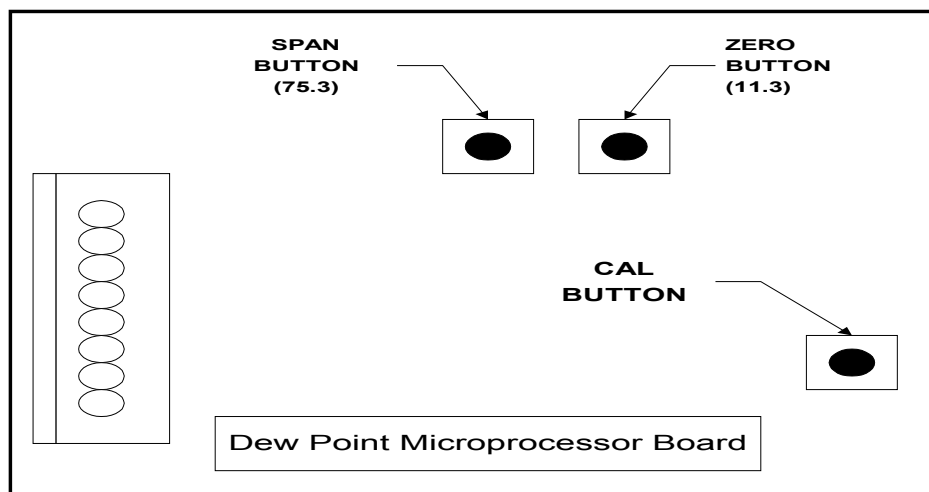

- 1.2 The **sensor-sampling chamber** is the gray rectangular box with brass barb fittings on either side with a black plastic gland protruding from the center.
- 1.3 The **sensor probe** is positioned in the sensor-sampling chamber. It is held in place by the nut on the black plastic gland.

2.0 Remove the sensor probe from the sensor sampling chamber.

- 2.1 Loosen the black plastic gland nut and slowly slide the sensor probe out through the airtight seal. Care must be taken when removing this sensor probe,

SSi Super Systems Inc.

Product Manual – Simple Dew - Dew Point Analyzer

since the tip is very delicate and can be easily damaged if it is mishandled. Note that the probe has white mark at the wire entry point, which must be aligned with corresponding white mark in plastic gland when it is re-inserted in the sampling chamber.

- 3.0 Install the sensor probe into the 75.3% salt solution.
 - 3.1 Slip the black sensor gland (supplied in the calibration kit) over the sensor probe with the sensor tip protruding from the threaded end of the gland and the sensor wires being flush with the top of the rubber o-ring in the gland. Tighten the gland around the sensor. This does not need to be done with a wrench or other tools, but it does need to be tight enough to prevent ambient air from contaminating the humidity level of the sampling chamber.
 - 3.2 Remove the cap of the 75.3% salt solution and install the sensor gland (with the sensor) into the salt solution. To increase the life of the calibration salts, an effort should be made to minimize the amount of time that the salt solution is exposed to the ambient air.
- 4.0 Allow the sensor to reach equilibrium with the calibration salt.
 - 4.1 Leave the sensor in the calibration salt for a minimum of eighteen (18) hours. It is acceptable to leave the sensor in the salt solution for a longer period of time, even a few days, if desired.
- 5.0 Begin the 75.3% (Span) calibration process.
 - 5.1 After leaving the sensor in the salt for at least eighteen (18) hours, turn the unit on (if it isn't on already).
 - 5.2 Simultaneously press the “75.3%” and “Calibration” buttons on the microprocessor board.
- 6.0 Verify the 75.3% (Span) calibration.
 - 6.1 Leave the sensor in the 75.3%RH calibration salt.
 - 6.2 Record the temperature and the dew point of the sensor. Since there is no display on the instrument, you will need to measure the voltage from the microprocessor board and translate that into the appropriate measurement.

SSi Super Systems Inc.

Product Manual – Simple Dew - Dew Point Analyzer

- 6.2.1 To determine the sensor temperature, measure the voltage between pins 5(+) and 9(-) on the microprocessor board. The voltage will be between 0 and 1VDC. Use the chart in Appendix A to determine the temperature in °F, or use Appendix B to determine the temperature in °C.
- 6.2.2 Temporarily record the sensor temperature.
- 6.3 Look up this temperature in Appendix “C” (Determining the Dew Point in °F) or Appendix “D” (Determining the Dew Point in °C). Appendix C will show the temperature values in Fahrenheit, and Appendix D will show the temperature values in Celsius.
- 6.4 Next to the appropriate sensor temperature, note the number in the corresponding column titled “75.3%”. This will match the measured dew point, which can be verified wherever the dew point is displayed.
- 7.0 After the 75.3% (Span) calibration has been completed, remove the sensor from the calibration salt and replace the cap on the salt.
- 7.1 Leave the sensor probe in the gland and while the unit is still on, allow it to achieve equilibrium at the ambient atmosphere in the room. This is accomplished by simply leaving the sensor exposed to ambient air for between two and three minutes. You will know when this has been accomplished when the numbers on the display begin to stabilize.
- 8.0 Install the sensor probe into the 11.3% salt solution.
- 8.1 Remove the cap of the 11.3% salt solution and install the sensor gland (with the sensor) into the salt solution. To increase the life of the calibration salts, an effort should be made to minimize the amount of time that the salt solution is exposed to the ambient air.
- 9.0 Allow the sensor to reach equilibrium with the calibration salt.
- 9.1 Leave the sensor in the calibration salt for a minimum of 24 hours. It is acceptable to leave the sensor in the salt solution for a longer period of time, even a few days, if desired.
- 10.0 Begin the 11.3% (Zero) calibration process

SSi Super Systems Inc.

Product Manual – Simple Dew - Dew Point Analyzer

- 10.1 After leaving the sensor in the salt for at least twenty-four (24) hours, turn the unit on (if it isn't on already).
 - 10.2 Simultaneously press the “11.3%” and “Calibration” buttons on the microprocessor board.
- 11.0 Verify the 11.3% (Zero) calibration
- 11.1 Leave the sensor in the 11.3%RH calibration salt
 - 11.2 Record the temperature and the dew point of the sensor. Since there is no display on the instrument, you will need to measure the voltage from the microprocessor board and translate that into the appropriate measurement.
 - 11.2.1 To determine the sensor temperature, measure the voltage between pins 5(+) and 9(-) on the microprocessor board. The voltage will be between 0 and 1VDC. Use the chart in Appendix A to determine the temperature in °F, or use Appendix B to determine the temperature in °C.
 - 11.2.2 Temporarily record the sensor temperature.
 - 11.3 Look up this temperature in Appendix “C” (Determining the Dew Point in °F) or Appendix “D” (Determining the Dew Point in °C). Appendix C will show the temperature values in Fahrenheit, and Appendix D will show the temperature values in Celsius.
 - 11.4 Next to the appropriate temperature, note the number in the corresponding column titled “11.3%”. This will match the measured dew point, which can be verified wherever the dew point is displayed.
- 12.0 After the 11.3% (Zero) calibration has been completed, remove the sensor from the calibration salt and replace the cap on the salt.
- 12.1 After the 11.3% (Zero) calibration has been completed, remove the sensor from the calibration salt and replace the cap.
- 13.0 Re-assemble the unit

SSi Super Systems Inc.

Product Manual – Simple Dew - Dew Point Analyzer

13.1 After the calibration process has been completed, remove the sensor probe from the gland and return it to the sensor-sampling chamber, taking care to position it properly. The white mark on the sensor probe should face towards the inlet tubing. If the white mark is not visible, then it should be placed so the sample flow directly strikes the face of the mirror on the sensor tip. In other words, the mirror should face the incoming gas stream.

13.2 Hand-tighten the black sensor gland to prevent air from leaking out of the sampling chamber.

14.0 Make sure that all caps are replaced on the calibration salts, and return the instrument to service.

SPARE PARTS –

To simplify the ordering of replacement parts, the following is a list of some of the components that may be requested:

Requires update

Description	Part Number
Factory Calibration	13045
Calibration Kit	31030
Bowl Filter	37048
Bowl Filter Element	31027
Dew Point Sensor	31038
Microprocessor Display Board	31501
Sensor Sampling Block	20192
Sample Tube`	20263
Sample Tube (With High-Temp Filter)	20264

SSi Super Systems Inc.

Product Manual – Simple Dew - Dew Point Analyzer

RETURNING THE UNIT TO SSi –

This analyzer contains some components that may require periodic replacement based on the amount of use that the unit experiences and the methods in which it is used. If service on the unit is necessary, it should be sent back to Super Systems, Inc. in the original packaging for repair. If the original packaging is not available, the analyzer should be surrounded by impact-absorbing materials and placed in a box. It is the responsibility of the shipper to ensure that the Simple Dew arrives at SSi undamaged.

Before shipping the analyzer, please call (800) 666-4330 to receive a Return Materials Authorization (RMA) number. The shipping address that should be used for returns is:

**Super Systems, Inc.
ATTN: RMA #XXXX
7205 Edington Drive
Cincinnati, OH 45249**

SSi Super Systems Inc.

Product Manual – Simple Dew - Dew Point Analyzer

APPENDIX “A” – (Determining the sensor temperature in °F)

When the DC voltage between 5(+) and 8(-) is:	Then the sensor temperature (°F) is:
0.3472	67.0
0.3478	67.2
0.3483	67.4
0.3489	67.6
0.3494	67.8
0.3500	68.0
0.3506	68.2
0.3511	68.4
0.3517	68.6
0.3522	68.8
0.3528	69.0
0.3533	69.2
0.3539	69.4
0.3544	69.6
0.3550	69.8
0.3556	70.0
0.3561	70.2
0.3567	70.4
0.3572	70.6
0.3578	70.8
0.3583	71.0
0.3589	71.2
0.3594	71.4
0.3600	71.6
0.3606	71.8
0.3611	72.0
0.3617	72.2
0.3622	72.4
0.3628	72.6
0.3633	72.8
0.3639	73.0
0.3644	73.2
0.3650	73.4
0.3656	73.6
0.3661	73.8
0.3667	74.0
0.3672	74.2
0.3678	74.4
0.3683	74.6
0.3689	74.8
0.3694	75.0
0.3700	75.2
0.3706	75.4
0.3711	75.6
0.3717	75.8
0.3722	76.0
0.3728	76.2
0.3733	76.4
0.3739	76.6
0.3744	76.8
0.3750	77.0
0.3756	77.2
0.3761	77.4
0.3767	77.6
0.3772	77.8
0.3778	78.0
0.3783	78.2
0.3789	78.4
0.3794	78.6
0.3800	78.8

When the DC voltage between 5(+) and 8(-) is:	Then the sensor temperature (°F) is:
0.3806	79.0
0.3811	79.2
0.3817	79.4
0.3822	79.6
0.3828	79.8
0.3833	80.0
0.3839	80.2
0.3844	80.4
0.3850	80.6
0.3856	80.8
0.3861	81.0
0.3867	81.2
0.3872	81.4
0.3878	81.6
0.3883	81.8
0.3889	82.0
0.3894	82.2
0.3900	82.4
0.3906	82.6
0.3911	82.8
0.3917	83.0
0.3922	83.2
0.3928	83.4
0.3933	83.6
0.3939	83.8
0.3944	84.0
0.3950	84.2
0.3956	84.4
0.3961	84.6
0.3967	84.8
0.3972	85.0
0.3978	85.2
0.3983	85.4
0.3989	85.6
0.3994	85.8
0.4000	86.0
0.4006	86.2
0.4011	86.4
0.4017	86.6
0.4022	86.8
0.4028	87.0
0.4033	87.2
0.4039	87.4
0.4044	87.6
0.4050	87.8
0.4056	88.0
0.4061	88.2
0.4067	88.4
0.4072	88.6
0.4078	88.8
0.4083	89.0
0.4089	89.2
0.4094	89.4
0.4100	89.6
0.4106	89.8
0.4111	90.0
0.4117	90.2
0.4122	90.4
0.4128	90.6
0.4133	90.8

When the DC voltage between 5(+) and 8(-) is:	Then the sensor temperature (°F) is:
0.4139	91.0
0.4144	91.2
0.4150	91.4
0.4156	91.6
0.4161	91.8
0.4167	92.0
0.4172	92.2
0.4178	92.4
0.4183	92.6
0.4189	92.8
0.4194	93.0
0.4200	93.2
0.4206	93.4
0.4211	93.6
0.4217	93.8
0.4222	94.0
0.4228	94.2
0.4233	94.4
0.4239	94.6
0.4244	94.8
0.4250	95.0
0.4256	95.2
0.4261	95.4
0.4267	95.6
0.4272	95.8
0.4278	96.0
0.4283	96.2
0.4289	96.4
0.4294	96.6
0.4300	96.8
0.4306	97.0
0.4311	97.2
0.4317	97.4
0.4322	97.6
0.4328	97.8
0.4333	98.0
0.4339	98.2
0.4344	98.4
0.4350	98.6
0.4356	98.8
0.4361	99.0
0.4367	99.2
0.4372	99.4
0.4378	99.6
0.4383	99.8
0.4389	100.0
0.4394	100.2
0.4400	100.4
0.4406	100.6
0.4411	100.8
0.4417	101.0
0.4422	101.2
0.4428	101.4
0.4433	101.6
0.4439	101.8
0.4444	102.0
0.4450	102.2
0.4456	102.4
0.4461	102.6
0.4467	102.8

SSi Super Systems Inc.

Product Manual – Simple Dew - Dew Point Analyzer

APPENDIX “B” – (Determining the sensor temperature in °C)

When the DC voltage between 5(+) and 8(-) is:	Then the sensor temperature (°C) is:
0.3472	19.4
0.3478	19.6
0.3483	19.7
0.3489	19.8
0.3494	19.9
0.3500	20.0
0.3506	20.1
0.3511	20.2
0.3517	20.3
0.3522	20.4
0.3528	20.6
0.3533	20.7
0.3539	20.8
0.3544	20.9
0.3550	21.0
0.3556	21.1
0.3561	21.2
0.3567	21.3
0.3572	21.4
0.3578	21.6
0.3583	21.7
0.3589	21.8
0.3594	21.9
0.3600	22.0
0.3606	22.1
0.3611	22.2
0.3617	22.3
0.3622	22.4
0.3628	22.6
0.3633	22.7
0.3639	22.8
0.3644	22.9
0.3650	23.0
0.3656	23.1
0.3661	23.2
0.3667	23.3
0.3672	23.4
0.3678	23.6
0.3683	23.7
0.3689	23.8
0.3694	23.9
0.3700	24.0
0.3706	24.1
0.3711	24.2
0.3717	24.3
0.3722	24.4
0.3728	24.6
0.3733	24.7
0.3739	24.8
0.3744	24.9
0.3750	25.0
0.3756	25.1
0.3761	25.2
0.3767	25.3
0.3772	25.4
0.3778	25.6
0.3783	25.7
0.3789	25.8
0.3794	25.9
0.3800	26.0

When the DC voltage between 5(+) and 8(-) is:	Then the sensor temperature (°C) is:
0.3806	26.1
0.3811	26.2
0.3817	26.3
0.3822	26.4
0.3828	26.6
0.3833	26.7
0.3839	26.8
0.3844	26.9
0.3850	27.0
0.3856	27.1
0.3861	27.2
0.3867	27.3
0.3872	27.4
0.3878	27.6
0.3883	27.7
0.3889	27.8
0.3894	27.9
0.3900	28.0
0.3906	28.1
0.3911	28.2
0.3917	28.3
0.3922	28.4
0.3928	28.6
0.3933	28.7
0.3939	28.8
0.3944	28.9
0.3950	29.0
0.3956	29.1
0.3961	29.2
0.3967	29.3
0.3972	29.4
0.3978	29.6
0.3983	29.7
0.3989	29.8
0.3994	29.9
0.4000	30.0
0.4006	30.1
0.4011	30.2
0.4017	30.3
0.4022	30.4
0.4028	30.6
0.4033	30.7
0.4039	30.8
0.4044	30.9
0.4050	31.0
0.4056	31.1
0.4061	31.2
0.4067	31.3
0.4072	31.4
0.4078	31.6
0.4083	31.7
0.4089	31.8
0.4094	31.9
0.4100	32.0
0.4106	32.1
0.4111	32.2
0.4117	32.3
0.4122	32.4
0.4128	32.6
0.4133	32.7

When the DC voltage between 5(+) and 8(-) is:	Then the sensor temperature (°C) is:
0.4139	32.8
0.4144	32.9
0.4150	33.0
0.4156	33.1
0.4161	33.2
0.4167	33.3
0.4172	33.4
0.4178	33.6
0.4183	33.7
0.4189	33.8
0.4194	33.9
0.4200	34.0
0.4206	34.1
0.4211	34.2
0.4217	34.3
0.4222	34.4
0.4228	34.6
0.4233	34.7
0.4239	34.8
0.4244	34.9
0.4250	35.0
0.4256	35.1
0.4261	35.2
0.4267	35.3
0.4272	35.4
0.4278	35.6
0.4283	35.7
0.4289	35.8
0.4294	35.9
0.4300	36.0
0.4306	36.1
0.4311	36.2
0.4317	36.3
0.4322	36.4
0.4328	36.6
0.4333	36.7
0.4339	36.8
0.4344	36.9
0.4350	37.0
0.4356	37.1
0.4361	37.2
0.4367	37.3
0.4372	37.4
0.4378	37.6
0.4383	37.7
0.4389	37.8
0.4394	37.9
0.4400	38.0
0.4406	38.1
0.4411	38.2
0.4417	38.3
0.4422	38.4
0.4428	38.6
0.4433	38.7
0.4439	38.8
0.4444	38.9
0.4450	39.0
0.4456	39.1
0.4461	39.2
0.4467	39.3

SSi Super Systems Inc.

Product Manual – Simple Dew - Dew Point Analyzer

APPENDIX “C” – (Determining the Dew Point in °F)

Sensor Temp (°F)	Percent RH	
	11.3%	75.3%
67.0	11.38	58.94
67.2	11.54	59.13
67.4	11.69	59.32
67.6	11.85	59.52
67.8	12.00	59.71
68.0	12.16	59.90
68.2	12.31	60.09
68.4	12.47	60.29
68.6	12.63	60.48
68.8	12.78	60.67
69.0	12.94	60.86
69.2	13.09	61.06
69.4	13.25	61.25
69.6	13.40	61.45
69.8	13.56	61.64
70.0	13.71	61.83
70.2	13.87	62.03
70.4	14.02	62.22
70.6	14.18	62.41
70.8	14.33	62.60
71.0	14.49	62.80
71.2	14.65	62.99
71.4	14.80	63.18
71.6	14.96	63.38
71.8	15.11	63.57
72.0	15.27	63.76
72.2	15.42	63.96
72.4	15.58	64.15
72.6	15.73	64.34
72.8	15.89	64.54
73.0	16.04	64.73
73.2	16.20	64.92
73.4	16.35	65.11
73.6	16.51	65.31
73.8	16.66	65.50
74.0	16.82	65.69
74.2	16.97	65.89
74.4	17.13	66.08
74.6	17.28	66.27
74.8	17.44	66.47
75.0	17.59	66.66
75.2	17.75	66.85
75.4	17.90	67.04

Sensor Temp (°F)	Percent RH	
	11.3%	75.3%
75.6	18.06	67.24
75.8	18.21	67.43
76.0	18.37	67.62
76.2	18.52	67.82
76.4	18.68	68.01
76.6	18.83	68.20
76.8	18.99	68.40
77.0	19.14	68.59
77.2	19.30	68.78
77.4	19.45	68.97
77.6	19.61	69.17
77.8	19.76	69.36
78.0	19.91	69.55
78.2	20.07	69.75
78.4	20.22	69.94
78.6	20.38	70.13
78.8	20.53	70.33
79.0	20.69	70.52
79.2	20.84	70.71
79.4	21.00	70.90
79.6	21.15	71.10
79.8	21.31	71.29
80.0	21.46	71.48
80.2	21.61	71.68
80.4	21.77	71.87
80.6	21.92	72.06
80.8	22.08	72.25
81.0	22.23	72.44
81.2	22.39	72.64
81.4	22.54	72.83
81.6	22.70	73.03
81.8	22.85	73.22
82.0	23.00	73.41
82.2	23.16	73.60
82.4	23.31	73.80
82.6	23.47	73.99
82.8	23.62	74.18
83.0	23.77	74.38
83.2	23.93	74.57
83.4	24.08	74.76
83.6	24.24	74.95
83.8	24.39	75.15
84.0	24.55	75.34

Sensor Temp (°F)	Percent RH	
	11.3%	75.3%
84.1	24.70	75.53
84.2	24.85	75.73
84.3	25.01	75.92
84.4	25.16	76.11
84.5	25.32	76.30
85.2	25.47	76.50
85.4	25.63	76.69
85.6	25.78	76.88
85.8	25.94	77.07
86.0	26.09	77.27
86.2	26.24	77.46
86.4	26.40	77.65
86.6	26.55	77.85
86.8	26.70	78.04
87.0	26.86	78.23
87.2	27.01	78.42
87.4	27.17	78.62
87.6	27.32	78.81
87.8	27.47	79.00
88.0	27.63	79.19
88.2	27.78	79.39
88.4	27.93	79.58
88.6	28.09	79.77
88.8	28.24	79.97
89.0	28.39	80.16
89.2	28.55	80.35
89.4	28.70	80.54
89.6	28.85	80.74
89.8	29.01	80.93
90.0	29.16	81.12
90.2	29.32	81.31
90.4	29.47	81.51
90.6	29.62	81.70
90.8	29.78	81.89
91.0	29.93	82.09
91.2	30.08	82.28
91.4	30.24	82.47
91.6	30.39	82.66
91.8	30.54	82.86
92.0	30.69	83.05
92.2	30.85	83.24
92.4	31.00	83.43
92.6	31.15	83.63

Sensor Temp (°F)	Percent RH	
	11.3%	75.3%
92.8	31.31	83.82
93.0	31.46	84.01
93.2	31.61	84.21
93.4	31.77	84.40
93.6	31.92	84.59
93.8	32.07	84.78
94.0	32.23	84.98
94.2	32.38	85.17
94.4	32.53	85.36
94.6	32.69	85.55
94.8	32.84	85.75
95.0	32.99	85.94
95.2	33.14	86.13
95.4	33.30	86.32
95.6	33.45	86.52
95.8	33.60	86.71
96.0	33.76	86.90
96.2	33.91	87.09
96.4	34.06	87.29
96.6	34.21	87.48
96.8	34.37	87.67
97.0	34.52	87.87
97.2	34.67	88.06
97.4	34.82	88.25
97.6	34.98	88.44
97.8	35.13	88.64
98.0	35.28	88.83
98.2	35.44	89.02
98.4	35.59	89.21
98.6	35.74	89.41
98.8	35.89	89.60
99.0	36.05	89.79
99.2	36.20	89.98
99.4	36.35	90.18
99.6	36.50	90.37
99.8	36.66	90.56
100.0	36.81	90.75
100.2	36.96	90.95
100.4	37.11	91.14
100.6	37.27	91.33
100.8	37.42	91.52
101.0	37.57	91.72
101.2	37.72	91.91

SSi Super Systems Inc.

Product Manual – Simple Dew - Dew Point Analyzer

APPENDIX “D” – (Determining the Dew Point in °C)

Sensor Temp (°F)	Percent RH	
	11.3%	75.3%
19.4	-11.46	14.97
19.6	-11.37	15.07
19.7	-11.28	15.18
19.8	-11.19	15.29
19.9	-11.11	15.39
20.0	-11.02	15.50
20.1	-10.94	15.61
20.2	-10.85	15.72
20.3	-10.76	15.82
20.4	-10.68	15.93
20.6	-10.59	16.03
20.7	-10.51	16.14
20.8	-10.42	16.25
20.9	-10.33	16.36
21.0	-10.24	16.47
21.1	-10.16	16.57
21.2	-10.07	16.68
21.3	-9.99	16.79
21.4	-9.90	16.89
21.6	-9.82	17.00
21.7	-9.73	17.11
21.8	-9.64	17.22
21.9	-9.56	17.32
22.0	-9.47	17.43
22.1	-9.38	17.54
22.2	-9.29	17.64
22.3	-9.21	17.76
22.4	-9.12	17.86
22.6	-9.04	17.97
22.7	-8.95	18.08
22.8	-8.87	18.18
22.9	-8.78	18.29
23.0	-8.69	18.39
23.1	-8.61	18.51
23.2	-8.52	18.61
23.3	-8.43	18.72
23.4	-8.35	18.83
23.6	-8.26	18.93
23.7	-8.18	19.04
23.8	-8.09	19.15
23.9	-8.01	19.26
24.0	-7.92	19.36
24.1	-7.83	19.47

Sensor Temp (°F)	Percent RH	
	11.3%	75.3%
24.2	-7.74	19.58
24.3	-7.66	19.68
24.4	-7.57	19.79
24.6	-7.49	19.90
24.7	-7.40	20.01
24.8	-7.32	20.11
24.9	-7.23	20.22
25.0	-7.14	20.33
25.1	-7.06	20.43
25.2	-6.97	20.54
25.3	-6.88	20.65
25.4	-6.80	20.76
25.6	-6.72	20.86
25.7	-6.63	20.97
25.8	-6.54	21.08
25.9	-6.46	21.18
26.0	-6.37	21.29
26.1	-6.28	21.40
26.2	-6.20	21.51
26.3	-6.11	21.61
26.4	-6.03	21.72
26.6	-5.94	21.83
26.7	-5.86	21.93
26.8	-5.77	22.04
26.9	-5.68	22.15
27.0	-5.60	22.26
27.1	-5.51	22.36
27.2	-5.43	22.47
27.3	-5.34	22.58
27.4	-5.26	22.68
27.6	-5.17	22.79
27.7	-5.08	22.90
27.8	-5.00	23.01
27.9	-4.91	23.11
28.0	-4.83	23.22
28.1	-4.74	23.33
28.2	-4.66	23.43
28.3	-4.57	23.54
28.4	-4.48	23.65
28.6	-4.40	23.76
28.7	-4.31	23.86
28.8	-4.23	23.97
28.9	-4.14	24.08

Sensor Temp (°F)	Percent RH	
	11.3%	75.3%
28.9	-4.06	24.18
29.0	-3.97	24.29
29.1	-3.88	24.40
29.1	-3.80	24.51
29.2	-3.71	24.61
29.6	-3.63	24.72
29.7	-3.54	24.83
29.8	-3.46	24.93
29.9	-3.37	25.04
30.0	-3.28	25.15
30.1	-3.20	25.26
30.2	-3.11	25.36
30.3	-3.03	25.47
30.4	-2.94	25.58
30.6	-2.86	25.68
30.7	-2.77	25.79
30.8	-2.68	25.90
30.9	-2.60	26.01
31.0	-2.52	26.11
31.1	-2.43	26.22
31.2	-2.34	26.33
31.3	-2.26	26.43
31.4	-2.17	26.54
31.6	-2.09	26.65
31.7	-2.01	26.76
31.8	-1.92	26.86
31.9	-1.83	26.97
32.0	-1.75	27.08
32.1	-1.66	27.18
32.2	-1.58	27.29
32.3	-1.49	27.39
32.4	-1.41	27.51
32.6	-1.32	27.61
32.7	-1.23	27.72
32.8	-1.15	27.83
32.9	-1.07	27.93
33.0	-0.98	28.04
33.1	-0.89	28.14
33.2	-0.81	28.26
33.3	-0.73	28.36
33.4	-0.64	28.47
33.6	-0.56	28.57
33.7	-0.47	28.68

Sensor Temp (°F)	Percent RH	
	11.3%	75.3%
33.8	-0.38	28.79
33.9	-0.30	28.89
34.0	-0.22	29.01
34.1	-0.13	29.11
34.2	-0.04	29.22
34.3	0.04	29.32
34.4	0.13	29.43
34.6	0.21	29.54
34.7	0.29	29.64
34.8	0.38	29.75
34.9	0.47	29.86
35.0	0.55	29.97
35.1	0.63	30.07
35.2	0.72	30.18
35.3	0.81	30.29
35.4	0.89	30.39
35.6	0.98	30.50
35.7	1.06	30.61
35.8	1.14	30.72
35.9	1.23	30.82
36.0	1.32	30.93
36.1	1.40	31.04
36.2	1.48	31.14
36.3	1.57	31.25
36.4	1.66	31.36
36.6	1.74	31.47
36.7	1.82	31.57
36.8	1.91	31.68
36.9	1.99	31.78
37.0	2.08	31.89
37.1	2.16	32.00
37.2	2.25	32.11
37.3	2.33	32.21
37.4	2.42	32.32
37.6	2.50	32.43
37.7	2.59	32.53
37.8	2.67	32.64
37.9	2.76	32.75
38.0	2.84	32.86
38.1	2.93	32.96
38.2	3.01	33.07
38.3	3.09	33.18
38.4	3.18	33.28

SSi Super Systems Inc.

Product Manual – Simple Dew - Dew Point Analyzer

Revision History

Rev No.	Description	Date	MCO #
-	Initial Release	3/6/2009	N/A